



HILEX[®]

FULL LINE PRODUCT CATALOG



BAG SOLUTIONS FOR BUSINESS

Hilex is the nation's premier manufacturer of poly packaging solutions including retail, produce, delivery, takeout bags and other customer focused systems. With industry-leading production capabilities and expertise, we support our customers every step of the way—from packaging development to production and consumer use. We offer solutions for businesses large and small that are convenient, cost effective and practical.

We make our bags from prime-grade materials, with options of virgin or recycled resin, optimized for strength, aesthetics and performance. As an innovator, we lead the industry in providing an extensive range of choices tailored to meet each of our customers' needs.

Hilex is also home to one of the largest plastic retail bag recycling centers. Our facility processes plastic bags collected at designated store drop-off locations and turns them into new retail bags using the recycled content. It's all part of the Novolex commitment to sustainability.



SUSTAINABILITY VISION

The Novolex vision for sustainability is to innovate more sustainable choices for our customers, operate responsibly and invest in our people and communities. We bring this vision to life every day through our ongoing focus on efficiency in our operations, as well as through partnerships with customers, suppliers, communities and others in the industry to develop solutions that reduce the impact our products can have on the environment.

For additional information, please visit www.novolex.com/novolex-sustainability/

04	Sustainability Partnerships and Certifications
05	How2Recycle® and Consumer Education
06	Film Materials
06	Mil and Micron
07	Seal Configuration
08	How to Measure a Bag
09	Bagging Techniques
	T-SHIRT BAGS
10	QuikMate EZ® T-Shirt Bags
10	Eco Blend® Thank You T-Shirt Bags
	PREMIUM T-SHIRT BAGS
11	Ultra Prime® Premium T-Shirt Bags
	REUSABLE BAGS
11	Ultra Prime® Reusable T-Shirt Bags
12	Ultra-Post™ Specialty Bags
12	Ultra-Post™ Reusable Specialty Bags
13	Non-Woven T-Shirt Bag and Handled Shoppers
13	Ultra-Post™ Sine Wave Reusable Bags
	SPECIALTY PLASTIC BAGS
14	Sine Wave Bags
14	Soft Loop Handle Bags
15	Die Cut Merchandise Bags
	E-COMMERCE BAGS
16	ProWave™ Tote
	FOOD DELIVERY BAGS
17	Load & Seal® Tamper-Evident Delivery Bags
	PRODUCE BAGGING SYSTEMS
18	RollStar® EZ Open™ Produce Bags
19	QuikStar® Self-Opening, Star Seal Header Bag (Produce Bags)
	CONVENIENCE STORE BAGGING SYSTEMS
20	RollMate® Bagging System
21	CheckMate™ Bagging System
21	Header Bagging System
	SPECIALTY PRODUCTS
22	Ice Bags
23	Trunk Liners



Novolex sustainability partnerships



The mark of responsible forestry

Forest Stewardship Council®

The FSC® promotes environmentally appropriate, socially beneficial, and economically viable management of the world's forests. The unique role of the FSC is to bring together people, organizations and businesses to develop consensus-based solutions that promote responsible stewardship of the world's forests.



Sustainable Forestry Initiative®

SFI® promotes sustainable forest management in North America and supporting responsible procurement globally. SFI directs all elements of the SFI program including the SFI forest management, fiber sourcing, and chain-of-custody standards, labeling and marketing. SFI certified products provide assurance that the paper used in these products represent a sound environmental choice with raw materials from certified forest content or certified sourcing. Novolex uses SFI Trademark License Code 01567.



Biodegradable Products Institute

BPI is North America's leading certifier of compostable products and packaging. Their certification program ensures that products and packaging displaying the BPI logo have been independently tested and verified according to scientifically based standards—ASTM D6400 or D6868 standards—for Novolex products. The BPI logo also helps industrial composters know that our products will break down as expected and contribute to healthy soil amendment.



Compost Manufacturing Alliance™

CMA is a global leader in providing industrial composting facilities an acceptance standard for compostable products. They perform field disintegration testing through several prominent processing methods to ensure products sent to industrial compost facilities adequately break down within the production cycle. CMA connects supply chain leaders with top compost manufacturing facilities nationwide to ensure mutual success as co-creators of compost and compostables.



American Society For Testing And Materials (ASTM)

This specification establishes the requirements for labeling of materials and products (including packaging), wherein a biodegradable plastic film or coating is attached (either through lamination or extrusion directly onto the paper) to compostable substrates and the entire product or package is designed to be composted in municipal and industrial aerobic composting facilities. In order to compost satisfactorily, the product must demonstrate each of the three characteristics as follows: (1) proper disintegration during composting; (2) adequate level of inherent biodegradation; and (3) no adverse impacts on the ability of composts to support plant growth.

How2Recycle® and consumer education

As part of our commitment to consumer education, Novolex uses the How2Recycle® and How2Compost™ labels on stock products and works with customers to encourage their use on branded items.



How2Recycle® is a standardized labeling system that clearly communicates recycling instructions to the public. When applicable, it includes instructions on how to properly clean a product before recycling.

How2Compost™ labels inform consumers if a product is compostable in commercial composting facilities. The label is available to use on packages that have gone through the Biodegradable Product Institutes (BPI) certification process. BPI certification is open to products that meets the requirements in ASTM D6400 or D6868 based on testing in a BPI-approved laboratory.

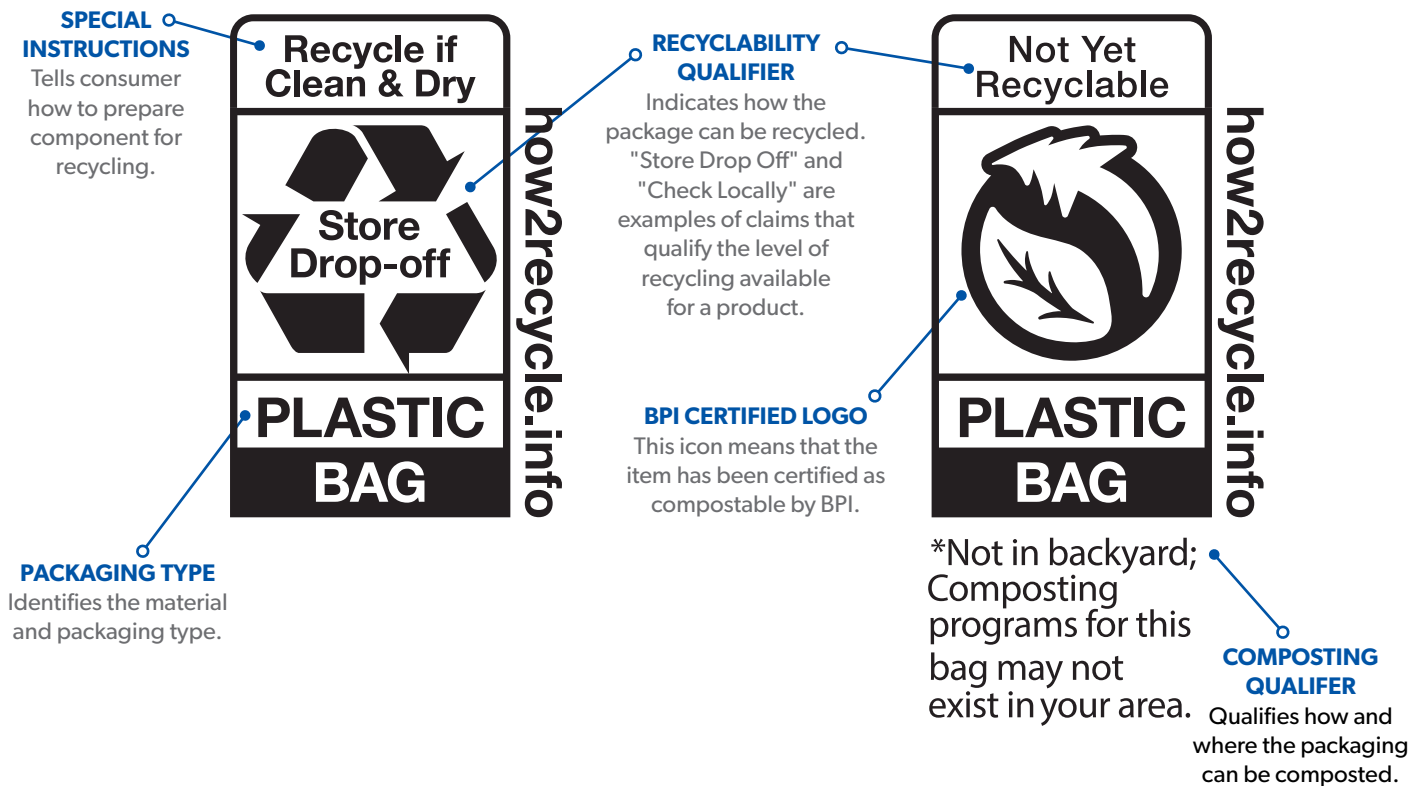

Film Materials

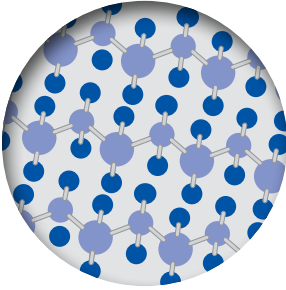
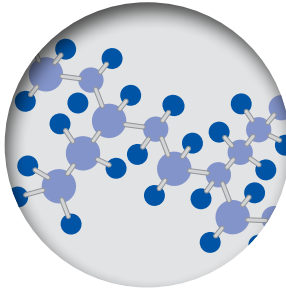
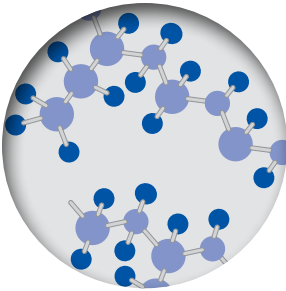
Plastic	Key Characteristics
 <p>High-Density (HDPE)</p>	<ul style="list-style-type: none"> • Makes “crinkly” sound when you move it—think of grocery T-Shirt bags • Harder to start or puncture a hole in than Low Density (LLD) • Once a hole is started, it may “zipper” • Thinner than LLD, but can hold same or greater weight as LLD • Gauge (thickness) measured in microns (mic) • Typical applications: T-Shirt bags and can liners • Substantial cost savings on a per bag basis • Recommended for paper, food, leaves and smooth heavy objects
 <p>Linear Low-Density (LLDPE)</p>	<ul style="list-style-type: none"> • Also referred to as “soft” film—quiet when moved, no “crinkly” sound • Easier to start or puncture a hole in than HDPE • A hole in this material will spread less quickly than it would in HDPE • Gauge (thickness) measured in mil • Recommended for high-gloss, sharp objects and tough transport conditions
 <p>HDPE/LDPE Co-Extruded</p>	<ul style="list-style-type: none"> • Also referred to as “COEX” film—softer than HDPE, but still some “crinkly” sound • Glossy outer (LDPE) surface + strong and tough (HDPE) inner layers • Harder to start or puncture a hole than with straight Low Density (LLD) • A hole in this material will spread less quickly than it would in straight HDPE • Gauge (thickness) measured in microns (mic) • Recommended for retailers who want an upscale-looking T-Shirt bag

Mil and Micron: 1 mil = 25.4 microns

Gauge	Definition
Mil	• A measurement equal to 1/1000 of an inch
Micron (μ)	• A metric unit of length equal to one millionth of a meter (micrometer)

Convert mic to mil equivalents																											
mic	6	7	8	9	10	11	12	13	14	15	16	17	18	19	20	21	22	23	24	25.40	30.50	38.10	43.20	50.8	57.2	76.2	101.6
mil	0.24	0.28	0.31	0.35	0.39	0.43	0.47	0.51	0.55	0.59	0.63	0.67	0.71	0.75	0.79	0.83	0.87	0.91	0.94	1.00	1.20	1.50	1.70	2.00	2.25	3.00	4.00

Seal Configuration

Transform a bag into an item that has an advantage all its own. With custom print available, options are virtually limitless. If you want a picture of the sky, you got it. If you want a bag to compliment your newest store display and signage, you can provide the idea and we will provide the solution. Create a bag that is fun to carry - for now and the future.

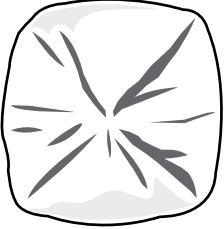
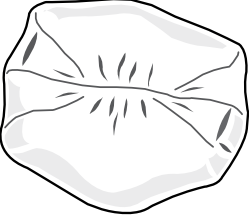
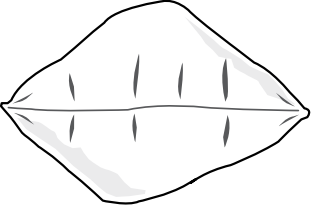
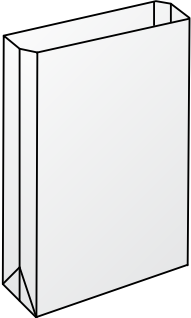
Seal	Key Characteristics
 <p data-bbox="462 548 578 615">Bottom Star Seal</p>	<ul data-bbox="651 485 1528 684" style="list-style-type: none"> • Most common seal in the HDPE produce roll bag markets • Bottom of the bag looks like a star or appears “bunched up” • Minimum leak potential • Star seals are designated by two dimensions: width x length (i.e. 15.00 x 20.00)
 <p data-bbox="462 814 618 882">Side Gusset Seal</p>	<ul data-bbox="651 747 1528 947" style="list-style-type: none"> • Forms a flat rectangular-shaped bottom • Both sides are tucked in to form a pleat or gusset • Conforms well to the shape of grocery and retail items • Gusseted bags are designated by three dimensions: width x gusset x height (i.e. 12.00 x 7.00 x 22.00)
 <p data-bbox="462 1119 573 1186">Bottom Flat Seal</p>	<ul data-bbox="651 1003 1528 1304" style="list-style-type: none"> • No gusset—has a flat seal along the bottom (resembles a pillow case) • Does not conform well to boxes or round items • Holds 15-20% more than a star seal bag of the same dimension • Medium leak potential • Used for bulk items (seed, candy, confections) • Flat seal bags are designated by two dimensions: width x length (e.g. 15.00 x 20.00)
 <p data-bbox="462 1486 583 1520">Side Seal</p>	<ul data-bbox="651 1356 1528 1656" style="list-style-type: none"> • Bag with seals along each side of the bag • The bottom may be formed with or without a bottom gusset • Bags with a bottom gusset bags open to form a flat bottom • Minimal leak potential • Used for wicket bags, sine wave bags and soft-loop handle bags • Side seal bags are designated by three dimensions: width x gusset x height (e.g. 21.00 x 8.00 x 20.00)

How to Measure a Bag

T-Shirt Bag

(Width x Gusset x Height)

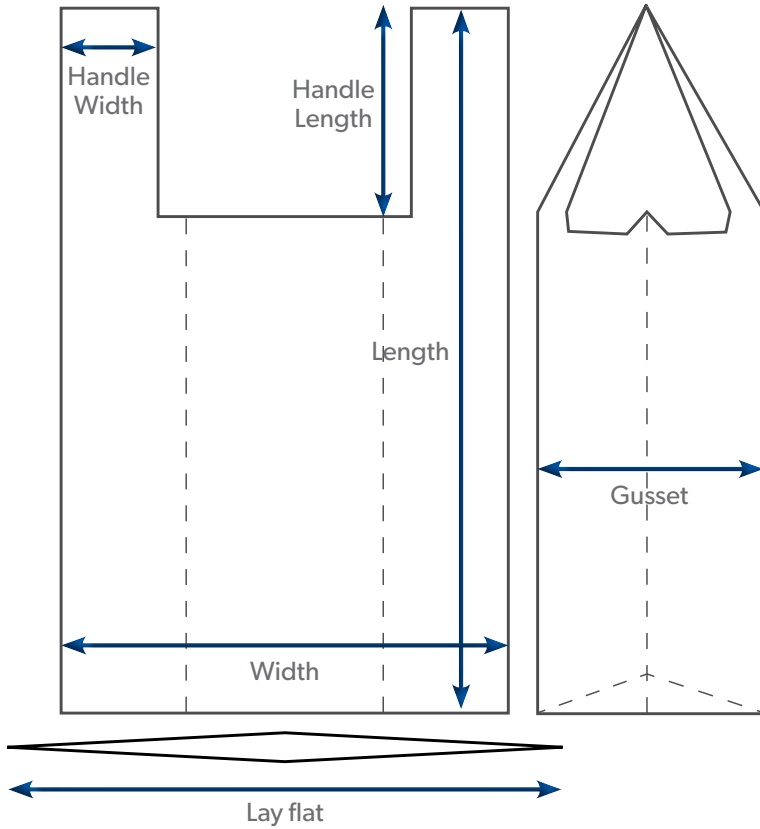

Soft Loop Handle Bag

(Width x Gusset x Height + Hem)

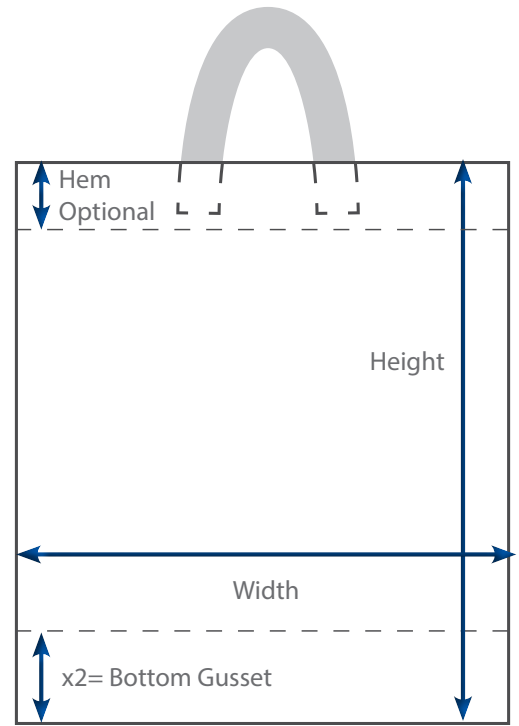

Sine Wave Bag

(Width x Height + Bottom Gusset + Wave Depth)

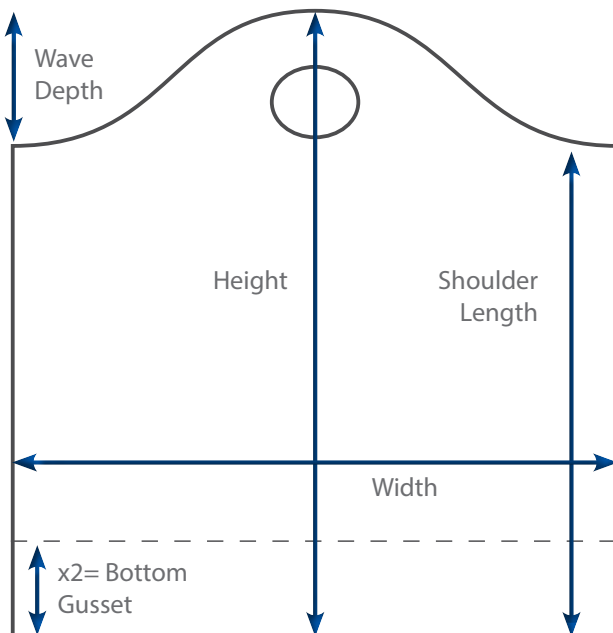

Die-Cut Handle Bag

(Width x Height or Width x Gusset x Height)

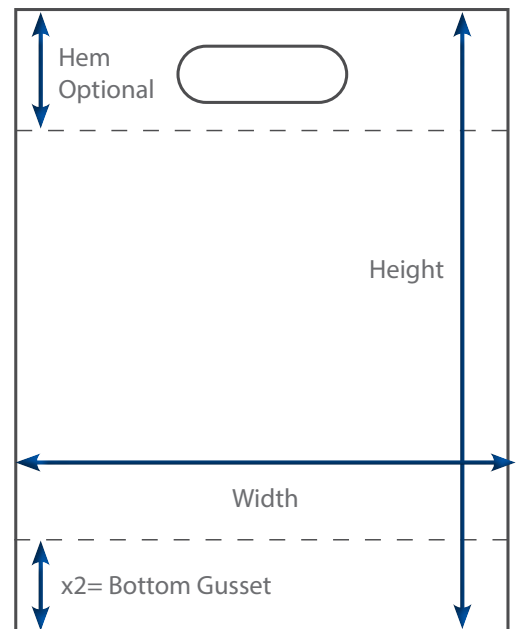

Bagging Techniques

What you put in your bag matters

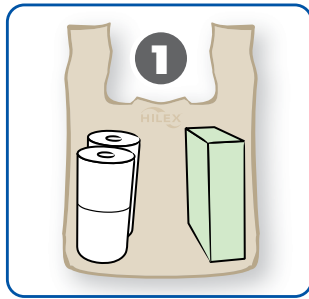

Build sides with any item except for crushable items.



Fill the bottom of the bag by utilizing any available space.



Place lighter items on top of the bottom layer.

Plan The Order

- A good bagger looks over the size of the order and plans the load.

Build Up The Walls

- Make a trim square bag, placing flat packages on the side of the sack, which builds up the walls, and gives the bag stability.
- Building up the walls also makes the bag easier to carry and forms a protective center (funnel) for breakable goods.

Place Small, Breakable Items In The Center

- Keep glass bottles and jars off the top of the bag.
- Put glass bottles and jars in the center (funnel) to ensure their protection.
- Always tighten caps on bottles before they are placed in the bag.

Pack It Solid

- Fill in gaps with small merchandise.
- A solid pack prevents shifting and cuts down on breakage.

Open The Bag Quickly

- Open the bag by putting both hands down through the center and squaring the bottom.

Split The Order For Equal Weight

- Don't overload the bag by putting the bulk of heavy merchandise in one bag.
- Balance the load by placing heavy items in two or three bags, the customer will appreciate this gesture, especially if the merchandise has to be carried up a flight of stairs.
- Heavy items should always be double bagged. Avoid bagging where appropriate – see special handling section.

Crushables

- Place crushables in a separate bag or on top of more solid, non-breakable items.
- Eggs, potato chips, soft fruits and vegetables, light bulbs, and bakery goods should be placed on top where they are free from pressure.
- Or place the crushables together in a separate plastic bag.

Build A Solid Foundation

- Build a square foundation and distribute the weight in the center of the bag by placing small cans, glass jars and other items in it.
- This strong base helps the bag to stand upright and makes it easier to carry. From this point, continue to build your load from heavy to light.
- Notice the word "place." Never throw items into the bag.
- Place the items with grace and speed, but never throw them.

Special Handling!

- **Ammonia, bleach and other chemicals should not be placed with food items.**
- **The residue on these items will contaminate the food. Avoid danger by double bagging these items separately.**
- **Don't bag large heavy items such as gallons of milk, gallons of bleach, gallons of water, sacks of vegetables, frozen turkeys, pet foods, laundry detergents, cases of soda and items with built in handles or carry assist capabilities.**

CAUTION

In order to avoid bag failure and potentially serious injury to person or property, at all times and for all interactions with the bags, please follow the below instructions:

- Maintain the integrity and structure of the bag, and prevent any scrapes, tears, abrasions, or holes; particularly when using bags along counters, in buggies, and against the consumer's goods.
- Never overload the bag with excess weight or with goods that may cause the bag to fail.
- Always use reasonable good judgment when packing bags with goods, and double bag the goods for extra protection or where necessary to avoid overload failure or goods that may cause the bag to fail, or as a last resort avoid bagging the goods altogether and place goods directly into the consumer's cart.

Sample Goods to Consider for Double Bagging:

- Metal Canned Goods
- Glass Bottles, Containers, or Jars
- Heavyweight Goods with unique or sharp edges or corners
- Any Goods with unique or sharp edges or corners.

When double bagging is warranted, the bagged merchandise should be picked up using all four bag handles.

Sample Goods to Consider to Avoid Bagging and for Placing Directly into Consumer's cart:

- Milk
- Two Liter Containers
- Large Wine Bottles
- Large Canned Goods
- Laundry Detergent
- Frozen Turkeys
- Any Goods with Built in Handles or Carry Assist Capabilities.

Use extra caution at all times when bagging goods and always use reasonable good judgment to avoid bag failure and potentially serious injury to person or property.

■ QuikMate EZ® T-Shirt Bags

PERFORMANCE FEATURES

- Engineered convenient T-Shirt bag style with integrated tabs
- Bag sizes to fit any purchase requirements
- Patented easy-open design
- Dispensing systems including racks, trays and compact dispensers for maximizing productivity
- Hardware to fit almost any check stand configuration
- Custom printing provides branding opportunity
- Jumbo T-Shirt bags are also available
- Compostable options available



Item #	Bag Dimensions (in.) W x G x H	Gauge (mic)	Description	Bag Per Case	Case Cube (ft³)	Ti/Hi	Min. Order
8553004	7.00 x 4.00 x 16.00	10.00	Mini	2000	0.24	16 x 6	6 Pallets
8108002	9.00 x 5.50 x 18.00	12.00	Junior	2000	0.54	20 x 3	6 Pallets
8023997	12.00 x 7.00 x 2.00	13.00	1/7	1000 or 2000	0.46	12 x 5	6 Pallets
1003426	12.00 x 7.00 x 22.00	13.00	1/6	1000 or 2000	0.46	12 x 5	6 Pallets
1009933	13.00 x 8.00 x 23.00	15.00	Supersize	1000	0.68	12 x 5	6 Pallets
1031360	11.50 x 6.50 x 21.00	25.4	Compostable T-Shirt bag	500	0.69	24 x 5	4 Pallets



Show your support during Breast Cancer Awareness Month with our PINK products.

Novolex has donated over \$75K to breast cancer research since 2015 and is pleased to offer you this unique way to show your support.

■ Eco Blend® Thank You T-Shirt Bags

PERFORMANCE FEATURES

- 40% recycled content available
- Strong T-Shirt bag with integrated tabs
- Patented easy-open design
- Designed to fit on standard front-end racks for easy loading
- Made with pride in the USA



Item #	Bag Dimensions (in.) W x G x H	Gauge (mic)	Film Color	Description	Print	Film Type	Case Pack	Nominal Case Weight	Ti/Hi	Min. Order
1031502	11.50 x 6.50 x 21.00	13.00	Black	High Recycled Content - 40%	Thank You	HDPE	1000	11.92	12 x 6	6 Pallets

For multiple truckload orders, please contact your Novolex sales representative to discuss availability. Colors are for reference only and may vary - please refer to physical film samples.

Ultra Prime® Premium T-Shirt Bags

PERFORMANCE FEATURES

- Made from prime grade materials, optimized for strength, aesthetics and performance
- Patented EZ Self-opening bag and rack system allows for convenient and easy packing of your take-out containers and other larger items
- Heavier gauge, increased opacity, and superior toughness
- Custom sizes and colors available in truckload quantities
- Available in standard or custom printing
- Cancer Awareness Program bags available



Item #	Bag Dimensions (in.) W x G x H	Volume Capacity (L)	Gauge (mic)	Film Color	Print	Film Type	Case Pack	Net Poly (lbs./Case)	Ti/Hi	Min. Order
1026175	11.50 x 7.50 x 21.00	15.60	15.00	Pure white	Thank You	HDPE	1500	21.90	12 x 4	6 Pallets
1027401	11.50 x 7.50 x 21.00	15.60	15.00	Pure white	Thank You	COEX	1500	21.90	12 x 4	6 Pallets
1027403	13.00 x 8.00 x 22.00	20.00	17.00	Pure white	Thank You	HDPE	1320	25.80	12 x 4	6 Pallets
1026304	13.00 x 8.00 x 22.00	20.00	17.00	Pure white	Thank You	COEX	1320	25.80	12 x 4	6 Pallets

Ultra Prime® Reusable T-Shirt Bags

PERFORMANCE FEATURES

- Tough reusable bag that encourages reuse
- Minimum 2.25 mil/57 mic gauge to meet most legislative requirements for reusable bags
- Made with a minimum of 20% recycled material
- Made with pride in the USA
- Designed to fit on standard front-end racks for easy loading
- Meets EcoLogo ATP-001 standard for legislative areas
- Custom prints available — contact your Novolex representative for details



Item #	Bag Dimensions (in.) W x G x H	Volume Capacity (L)	Gauge (mil/mic)	Film Color*	Print	Film Type	Case Pack	Net Poly (lbs./Case)	Ti/Hi	Min. Order
1028338	11.50 x 6.50 x 21.00	15.70	2.25 / 57.20	White	Thank You	LDPE or MDPE	500	26.16	12 x 3	6 Pallets
1031191	11.50 x 6.50 x 21.00	15.70	2.25 / 57.20	Light gray	Thank You	LDPE or MDPE	500	26.16	12 x 3	6 Pallets
1029846	12.00 x 8.00 x 22.00	18.90	2.25 / 57.20	White	Thank You	LDPE or MDPE	500	30.52	12 x 3	6 Pallets
1030154	11.50 x 6.50 x 21.00	15.70	3.00 / 76.20	White	Thank You	LDPE	375	26.16	12 x 3	6 Pallets
1030676	11.50 x 6.50 x 21.00	15.70	4.00 / 101.60	White	NEW Reuse Hex	LDPE w/20% PCR	250	23.40	12 x 3	6 Pallets

*Due to recycled content, there may be slight variations in color

■ Ultra-Post™ Reusable T-Shirt Bags

PERFORMANCE FEATURES

- Tough reusable bag that encourages reuse
- Minimum 2.25 mil/57 mic gauge to meet most legislative requirements for reusable bags
- Made with a minimum of 40% post-consumer recycled third party certified material
- Made with pride in the USA
- Designed to fit on standard front-end racks for easy loading
- Meets EcoLogo ATP-001 standard for legislative areas and is compliant with California Senate Bill 270 standards
- Custom prints available — contact your Novolex representative for details



Item #	Bag Dimensions (in.) W x G x H	Volume Capacity (L)	Gauge (mil/mic)	Film Color*	Print	Film Type	Case Pack	Net Poly (lbs./Case)	Ti/Hi	Min. Order
1028278	11.50 x 6.50 x 21.00	15.70	2.25 / 57.20	White	Thank You	LDPE	500	26.16	12 x 3	6 Pallets
1028321	11.50 x 6.50 x 21.00	15.70	2.25 / 57.20	Light gray	Thank You	LDPE	500	26.16	12 x 3	6 Pallets
1029646	11.50 x 6.50 x 21.00	15.70	2.25 / 57.20	White	Thank You	MDPE	500	26.16	12 x 3	6 Pallets
1028323	11.50 x 6.50 x 21.00	15.70	2.25 / 57.20	Light gray	Thank You	MDPE	500	26.16	12 x 3	6 Pallets
1028648	11.50 x 6.50 x 21.00	15.70	2.25 / 57.20	White	Reuse - Hex	LDPE	500	26.16	12 x 3	6 Pallets
1028649	11.50 x 6.50 x 21.00	15.70	2.25 / 57.20	Light gray	Reuse - Hex	LDPE	500	26.16	12 x 3	6 Pallets

*Due to recycled content, there may be slight variations in color

■ Ultra-Post™ Reusable Specialty Bags

PERFORMANCE FEATURES

- Made with a minimum of 40% recycled material
- Tough reusable bag that encourages reuse
- Minimum 2.25 mil thick to meet most legislative requirements for reusable bags
- Made with pride in the USA
- Custom prints available — contact your Novolex representative for details



Sine Wave

Item #	Bag Dimensions (in.) W x H x G + (Wave Depth)	Gauge (mil/mic)	Volume Capacity (L)	Film Color*	Print	Case Pack	Net Poly (lbs./Case)	Min. Order
1030901	18.00 x 17.00 x 6.00 + 5.00	2.25 / 57.20	15.70	White	Thank You	250	12.19	6 Pallets
1030616	18.00 x 17.00 x 6.00 + 5.00	3.00 / 76.20	15.70	White	Reuse Hex	250	16.11	6 Pallets
1030615	18.00 x 17.00 x 6.00 + 5.00	4.00 / 101.60	15.70	White	Reuse Hex	250	21.51	6 Pallets

Soft Loop Handle

Item #	Bag Dimensions (in.) W x H x G + (Wave Depth)	Gauge (mil/mic)	Volume Capacity (L)	Film Color*	Print	Case Pack	Net Poly (lbs./Case)	Min. Order
1030883	18.00 x 14.00 + 6.00	2.25 / 57.20	19.00	White	Thank You	250	16.15	12 Pallets
1030144	18.00 x 14.00 + 6.00	3.00 / 76.20	19.00	White	Reuse Hex	250	17.32	12 Pallets
1030145	18.00 x 14.00 + 6.00	4.00 / 101.60	19.00	White	Reuse Hex	250	22.69	12 Pallets

*Due to recycled content, there may be slight variations in color

Ultra-Post™ Sine Wave Reusable Bags

PERFORMANCE FEATURES

- Tough reusable bag that encourages reuse
- Minimum 2.25 mil thick to meet most legislative requirements for reusable bags
- Made with a minimum of 40% post-consumer recycled third party certified material
- Made with pride in the USA
- Meets EcoLogo ATP-001 standard for legislative areas and is compliant with California Senate Bill 270 standards
- Custom prints available — contact your Novolex representative for details



Item #	Bag Dimensions (in.) W x H x G + (Wave Depth)	Gauge (mil/mic)	Volume Capacity (L)	Film Color*	Print	Case Pack	Net Poly (lbs./Case)	Min. Order
1031532	18.00 x 16.00 x 6.00 + 5.00	2.25 / 57.20	15.10	White	Reusable and Recyclable	500	22.96	6 Pallets
1031533	21.00 x 18.00 x 9.00 + 7.00	2.25 / 57.20	20.30	White	Reusable and Recyclable	500	30.96	6 Pallets
1031534	24.00 x 20.00 x 10.00 + 7.00	2.25 / 57.20	31.30	White	Reusable and Recyclable	250	20.07	6 Pallets

Non-Woven T-Shirt Bag and Handled Shoppers

PERFORMANCE FEATURES

- Tough, reusable bags that encourage reuse
- 80 GSM to meet most legislative requirements for reusable bags
- Cut outs for bags to fit on front end racks for easy loading
- Custom sizes and colors are available
- Made from lightweight yet durable non-woven polypropylene
- Washable bags can be reused multiple times
- Reuse Hex print



Item	Bag Dimensions (in.) W x G x H	Volume Capacity (L)	Thickness	Film Color	Bag Style	Film Type	Case Pack	Net Poly (lbs./Case)	Ti-Hi
1030782	11.50 x 6.50 x 21.00	15.70	80 GSM	Black	T-Shirt	NWPP Fabric	250	20.50	6 x 2
1030786	14.00 x 8.00 x 15.00	27.50	80 GSM	Black	Handled	NWPP Fabric	100	11.54	9 x 6
1031756	14.00 x 8.00 x 15.00	27.50	80 GSM	Black	Handled	NWPP Fabric with 30% PCR	100	11.54	9 x 6

Sine Wave Bags

PERFORMANCE FEATURES

- Wide opening for easy loading
- Flat bottom gusset keeps items secure and allows bag to stand on its own
- Multiple film colors available
- Available in multiple sizes with expandable gussets for larger items
- Integrated handles for ease in carrying
- Custom sizes and print available—contact your Hilex Poly representative for details

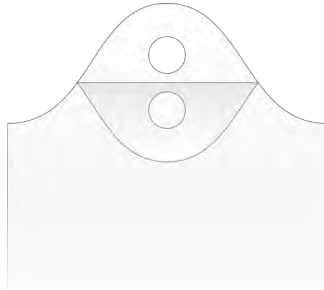

Easy-opening, pre-folded, front-side-free handle option available



Item #	Dimensions (in.) W x H x BG	Bottom Dimensions (in.) W x L	HDPE Gauge (mil)	Description	Compares to Paper Shopper	Case Pack	Case Net Weight (lbs.)	Case Cube (ft ³)	Cases/Pallet
1030873	18 x 16 x 9	9 x 9	1.20	Carryout bag white	Bistro, Regal or 1/7 BBL Grocery	500	13.50	0.44	60
1029114	21 x 18 x 10	11 x 10	1.50	Carryout bag white	Royal or Regal	500	21.50	0.67	48
1031031	24 x 20 x 10	14 x 10	2.00	Carryout bag white	Super Royal	500	16.76	0.53	48

Soft Loop Handle Bags

PERFORMANCE FEATURES

- The premium retail or foodservice bag
- Heavy gauge HDPE or LDPE body
- Soft loop LDPE handle
- Bottom or side gusset
- Flat bottom keeps items from tipping or leaking
- Integrated soft loop handle for ease in carrying
- Available in a variety of sizes and film colors
- Custom printing available



Item #	Bag Dimensions (in.) W x H x BG	Bottom Dimensions (in.)	Gauge (mil)	Film Color	Description	Case Pack	Net Wt. (lbs.)	Case Size (in.) W x L x H	Ti/Hi	Min. Orders
1031384	18.00 x 12.00 x 8.00	10.00 x 8.00	2.00	White	Soft Loop Bistro	500	21.59	23.00 x 13.00 x 3.92	6 x 10	4 pallets
1031383	21.00 x 13.00 x 9.00	12.00 x 9.00	2.00	White	Soft Loop Regal	500	26.00	23.00 x 10.00 x 4.75	8 x 7	4 pallets
1031394	24.00 x 14.00 x 10.00	14.00 x 10.00	2.00	White	Soft Loop Super Royal	250	16.48	25.00 x 11.25 x 3.25	6 x 10	8 pallets

Die Cut Merchandise Bags

PERFORMANCE FEATURES

- Wide opening for easy loading
- Die cut handle for ease in carrying
- High density and low density film available in multiple colors
- Available in both side or bottom gussets
- Available in multiple sizes with expandable gussets for larger items
- Custom printing available



Available Tab Styles

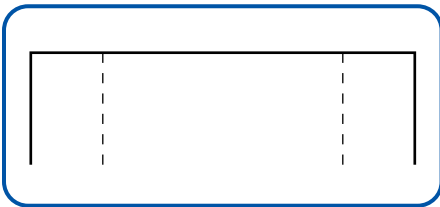

Loose pack

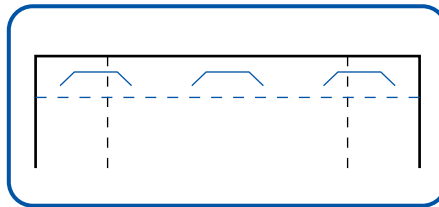

Blocked header

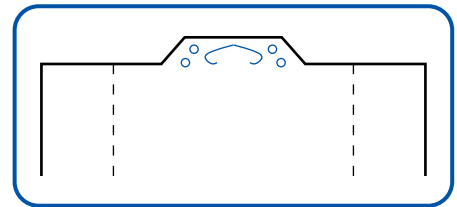

Integral header

Available Handle Styles

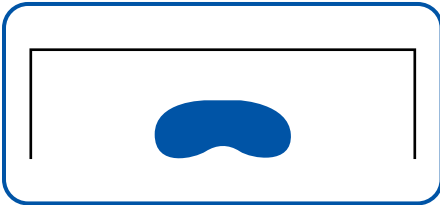

Kidney handle

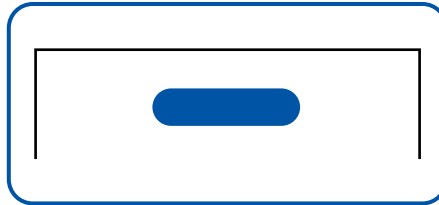

1.00" x 3.00" racetrack handles

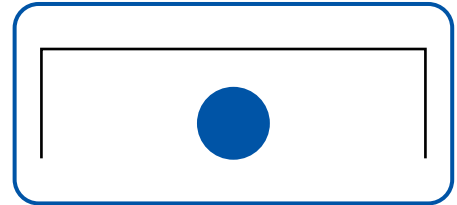

2.00" round hole handle

Available Seal Styles

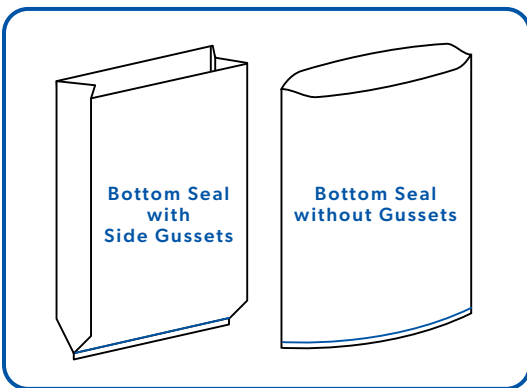

Bottom Seal Features

- Available in HDPE or COEX Film

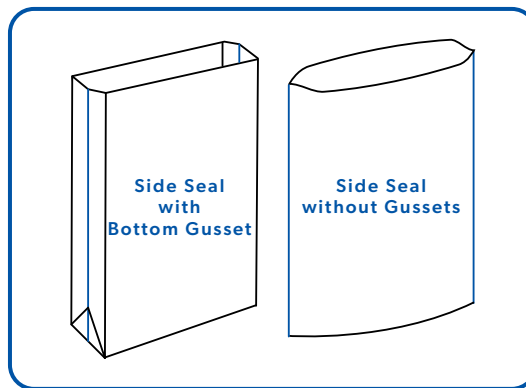

Side Seal Features

- Manufactured with a variety of options – with/without: gusset, hemmed top, handle
- Available in LDPE, HDPE or COEX Film

ProWave™ Tote

PERFORMANCE FEATURES

- Made from minimum 20% recycled content, or from at least 40% Post-Consumer Material
- Low profile design and flat bottom for easy loading
- Large, comfortable handles for carrying
- Fully customizable options for increased brand awareness and marketing
- Options available to meet legislative standards
- Made from heavy gauge polyethylene that stands up for loading
- Unique handle and upper flaps provide extra security to keep contents in the bag



Open the Bag

Snap the bag open to square up the flat bottom

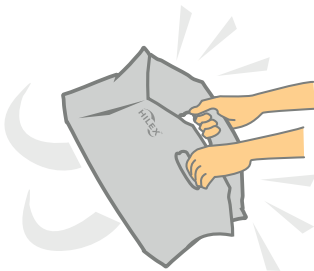

1. Build Side Walls

- Cereal boxes*
- Pancake mix*
- Toilet paper
- Frozen dinners
- Paper plates
- Frozen waffles

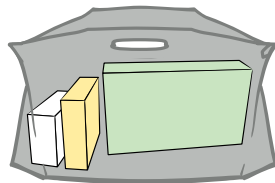

2. Fill the Base

- Canned vegetables
- Condiments
- Canned fruit
- Butter
- Peanut butter
- Block cheeses
- Soup

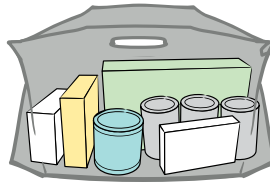

3. Fill it Up

- Lighter items
- Spices
- Small boxes
- Noodles
- Facial tissue
- Bagged cheese
- Jello
- Cotton balls

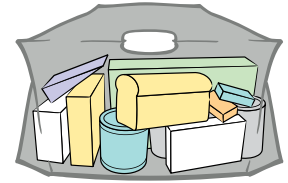

*High profile boxes should be placed on their sides for optimal packing

Item #	Bag Dimensions (in.) W x H x BG	Gauge (mil/mic)	Film Color	Print	Film Type	Case Pack	Net Poly (lbs./Case)	Carton Size (in) W x L x H	Case Cube (ft ³)	Ti/Hi	Min. Order
1031495	22.00 x 12.00 x 7.00	1.70 / 43.20	Kraft	Recyclable & Reusable	MDPE	625	28.39	12.40 x 11.70 x 9.40	0.79	12 x 3	10 Pallets
1031238	22.00 x 12.00 x 7.00	2.25 / 57.20	Cool gray	Recyclable & Reusable	MDPE	500	31.23	12.40 x 11.70 x 9.40	0.79	12 x 3	10 Pallets
1031199	22.00 x 12.00 x 7.00	2.25 / 57.20	Kraft	Recyclable & Reusable	MDPE	500	31.23	12.40 x 11.70 x 9.40	0.79	12 x 3	10 Pallets
1031283	22.00 x 12.00 x 7.00	2.25 / 57.20	White	Recyclable & Reusable	MDPE	500	31.23	12.40 x 11.70 x 9.40	0.79	12 x 3	10 Pallets
1031676	22.00 x 12.00 x 7.00	2.25 / 57.20	Cool gray	Recyclable & Reusable – 40% PCR	MDPE	500	31.23	12.40 x 11.70 x 9.40	0.79	12 x 3	10 Pallets

Load & Seal® Tamper-Evident Delivery Bags

PERFORMANCE FEATURES

- Easy to load
- Tamper-evident closure discourages pilferage and contamination
- Vents to allow steam to escape
- Custom printing, size and gauge are available
- Translucent stock bags also available
- Custom case count available by truckload quantities only

KEY FEATURES

- 1 Inner adhesive strip for easy, secure closure
- 2 Removable strip is BLUE for easy identification
- 3 Specially engineered perforation providing transport strength and easy customer access
- 4 Butterfly vent holes (4 on each side)
- 5 All items are secure with every delivery



Versatile Size

Perfectly sized to fit 3 large containers, side dishes and or dry goods.

Item #	Bag Size (In.) W x H x G	Gauge (mil)	Film Color	Film Type	Print	Bags/Case	Case Weight (lbs.)	Ti/Hi	Bottom Dimensions (in.)
1030667	21.00 x 17.00 x 9.00	1.50	Natural	HDPE	Thank You	500	21.94	6 x 6	Squares to 12.00 x 9.00

RollStar® EZ Open™ Produce Bags

PERFORMANCE FEATURES

- New formulation improves shopper experience with easier-to-open bags
- Star seal bottom bags are leak-proof and stronger than conventional flat seal bags
- Universal narrow roll bag dispenser fits in a variety of spaces and is compatible with most roll bags
- Multiple bag sizes and prints for other departments including bakery, meat and seafood products
- Custom fixtures and prints available
- Multiple manufacturing facilities ensures business continuity for single source customers
- 1 pallet MOQ for stock RollStar produce bags
- RollStar Compostable is BPI Certified



DISPENSING SYSTEM

We can assist you in selecting the right dispensing system for your needs.



Item #	Dimensions (in.) Lay-Flat W x L	Folded Width (in.)	Gauge (mic)	Film Color	Description	Print	Bags Per Roll	Bags Per Case	Net Poly (lbs./ Case)	Case Cube (ft ³)	Cases Per Pallet
1019159	14.00 x 18.00	3.75	6.00	Natural	Medium produce	More Matters	1000	4000	16.35	0.49	60
1027759	14.00 x 18.00	3.75	8.00	Natural	Medium produce	More Matters	750	3000	16.35	0.49	60
1018878	12.00 x 20.00	3.25	8.00	Natural	Standard produce	More Matters	750	3000	15.57	0.51	60
1031327	12.00 x 20.00	3.25	8.00	Green Tint	Standard produce – 30% recycled	More Matters	750	3000	15.57	0.51	60
1019160	15.00 x 20.00	4.00	6.00	Natural	Large produce	More Matters	1000	4000	19.47	0.57	60
1030417	15.00 x 20.00	4.00	6.00	Natural	Large produce	More Matters	825	3300	16.06	0.57	60
1018547	15.00 x 20.00	4.00	8.00	Natural	Large produce, medium	More Matters	750	3000	19.47	0.55	60
1028752	15.00 x 20.00	4.00	8.00	Yellow Tint	Organic	Organic	750	3000	19.47	0.55	60
1031583	15.00 x 20.00	4.00	8.00	Natural	Safe handling (meat bag)	Safe Handling	750	3000	19.47	0.55	60
1018882	15.00 x 20.00	4.00	10.00	Natural	Bakery	Bakery	600	2400	19.47	0.62	60
1018883	16.00 x 26.00	4.25	8.00	Natural	Leafy greens	More Matters	575	2300	20.70	0.57	60
1018884	16.00 x 26.00	4.25	15.00	Natural	Corn & yams	More Matters	300	1200	20.25	0.64	60
1029616	15.00 x 20.00	4.00	15.00	Red Tint	Red meat bag	Safe Handling	250	1500	18.25	0.64	60
1029618	15.00 x 20.00	4.00	15.00	Blue Tint	Fresh seafood bag	Fresh Seafood	250	1500	18.25	0.64	60
1031728	15.00 x 20.00	4.00	6.00	Natural	Small roll RollStar®	Plain w/Warning	100	3000	14.60	0.60	60
1029972	15.00 x 20.00	4.00	6.00	Yellow Tint	Organic small roll	Organic	100	3000	14.60	0.60	60
1029971	15.00 x 20.00	4.00	6.00	Red Tint	Safe handling (small roll)	Safe Handling	100	3000	14.60	0.60	60
1031025	14.00 x 18.00	3.75	10.00	Green Tint	RollStar – compostable	RollStar Compostable	300	1800	16.32	0.43	80
1032089	15.00 x 18.00	3.75	10.00	Green Tint	RollStar – compostable	RollStar Compostable	300	1800	19.05	0.43	80

■ QuikStar® Self-Opening, Star Seal Header Bag (Produce Bags)

PERFORMANCE FEATURES

- Variety of dispensing options: on partitions, wet case walls or floor stands
- Patented EZ self-opening bags provide one-at-a-time pinch and pull dispensing to eliminate bag waste and shopper frustration
- Multiple bag sizes and films match the bag to the produce (standard, organic, greens, corn/yams)
- Anytime restocking so dispensers never run out, shoppers are never empty handed
- Integral tab, headerless design leaves nothing behind on the rack or in your department
- Star seal bottom—the strongest seal option
- Stock or custom prints to promote your brand
- Compostable option available

QUIKSTAR DISPENSING OPTIONS



Spring wire hook
(Item # 777-3434)



Compact dispenser
(Item # 777-3550)



Single bag well dispenser
(Item # 777-3489)



Item #	Dimensions (in.) W x L	Folded Width (in.)	Gauge (mic)	Film Color	Description	Print	Bags/ Case	Bags/ Hand	Hands/ Case	Case Weight (lbs.)	Case Cube (ft ³)	Min. Order
1003805	12.00 x 16.00	3.25	8.00	Natural	Standard produce	5 A Day	4020	67	60	17.10	0.56	1 pallet
1007641	12.00 x 20.00	3.25	8.00	Natural	Plain QS 12 x 20	Plain, French/ English Warning	4000	67	60	21.70	0.67	1 pallet
1003778	15.00 x 20.00	4.00	8.00	Natural	Ex-large produce	5 A Day	4020	67	60	26.00	0.96	1 pallet
1024239	15.00 x 20.00	4.00	8.00	Green tint	Organic	Organic	4020	67	60	26.00	0.96	1 pallet
1003779	15.50 x 24.00	4.25	10.00	Green tint	Leafy greens	5 A Day	3000	50	60	31.00	0.98	1 pallet
1003754	15.50 x 24.00	4.25	15.00	Yellow tint	Corn & yams	Corn & Yams	2000	40	50	31.00	0.98	1 pallet

RollMate® Bagging System

PERFORMANCE FEATURES

- Compact dispensers reduce space requirements by up to 80%, compared to conventional bags and systems
- Space-saving roll dispensers to mix and match bag sizes
- Up to 500 bags per roll means there's less restocking
- Multiple hardware kits allow under-the-counter or end-of-counter installation, eliminating checkout clutter
- Custom printing provides branding opportunity (Stock designs also available)
- Jumbo size also available, (22.00" x 10.00" x 38.00")



Space-saving hardware

Item #	Bag Dimensions (in.) W x G x H	Gauge (mic)	Film Color	Description	Print	Bags/ Case	Case Weight (lbs.)	Carton Size (in) W x L x H	Case Cube (ft ³)	Ti/Hi	Min. Order
1006378	9.50 x 6.00 x 18.00	10.00	White	Medium	Happy Face	2000 / 4 rolls	13.08	10.06x10.06x9.1	0.68	16 x 3	1 pallet
8028078	9.50 x 6.00 x 18.00	10.00	White	Medium	Neighborhood	2000 / 4 rolls	13.08	10.06x10.06x9.1	0.68	16 x 3	1 pallet
1006379	11.00 x 6.50 x 22.00	12.00	White	Large	Happy Face	1600 / 4 rolls	17.35	10.12x10.12x11.02	0.81	16 x 3	1 pallet
8035012	11.00 x 6.50 x 22.00	12.00	White	Large	Neighborhood	1600 / 4 rolls	17.35	10.12x10.12x11.02	0.81	16 x 3	1 pallet
8035017	11.00 x 6.50 x 22.00	12.00	White	Large	Plain w/warning	1600 / 4 rolls	17.35	10.12x10.12x11.02	0.81	16 x 3	1 pallet
8107027	15.00 x 8.00 x 26.50	12.00	White	Large plus	Thank you	1500 / 4 rolls	25.67	11.1x11.1x15.04	1.07	12 x 3	1 pallet
8609034	18.00 x 8.00 x 34.00	14.00	White	X-large	Thank you	1000 / 4 rolls	30.04	11.08x11.08x18.04	1.40	16 x 2	1 pallet

■ CheckMate™ Bagging System

PERFORMANCE FEATURES

- Expedite cash-wrap transactions using the complete dispensing system
- Provides one-at-a-time bag dispensing
- Under-the-counter installation option
- Units can be stacked or mounted side by side
- Bags are packed in light weight pouches
- User-friendly dispenser units
- Strong integral tab feature
- Bag self opens upon removal
- Easy to install



Item #	Bag Dimensions (in.) W x G x H	Gauge (mic)	Film Color	Description	Print	Bags/Case	Case Weight (lbs.)	Ti/Hi
1018061	9.00 x 6.00 x 18.00	11.00	White	Small	Thank You	1000 (5 sleeves of 200)	7.21	12 x 8
1018140	12.00 x 7.00 x 21.00	14.00	White	Large	Thank You	1000 (5 sleeves of 200)	13.25	9 x 7

■ Header Bagging System

PERFORMANCE FEATURES

- The header bag that sets the standard for versatility
- One-at-a-time dispensing reduces waste and clutter
- Versatile hardware is easy to install wherever bags are needed
- Convenient placement within easy reach of customers
- Bag is available with or without side gusset
- Multiple bag size options
- Optional handles for easier carrying



This item is available by custom order only. Contact your Novolex Sales Representative for additional information.

Ice Bags

PERFORMANCE FEATURES

- Wire wickets
- Plastic wickets
- Drawstring design
- Flat packs
- Custom sizes ranging from 3 lb. –w 50 lb. bags
- Custom and stock prints available



Wire Wicket



Plastic wicket



Drawstring



Ice Box Kit (Item #777-3942)

Flat/Loose

Item #	Dimensions (in.) W x L	Gauge (mil)	Description	Case Pack	Ti/Hi	Min. Order
1016933	11.00 x 19.00	1.15	8 lb ice bag flat/loose	500	12 x 4	1 Pallet
1015766	11.00 x 19.00	1.15	8 lb ice bag flat/loose	1000	12 x 4	1 Pallet
1016935	12.00 x 22.00	1.15	10 lb ice bag flat/loose	500	12 x 4	1 pallet
1015769	12.00 x 22.00	1.15	10 lb ice bag flat/loose 1m/cs	1000	12 x 4	1 Pallet

Wire Wicket

Item #	Dimensions (in.) W x L + (Lip)	Gauge (mil)	Description	Case Pack	Ti/Hi	Min. Order
1015767	11.00 x 19.00 + 1.50	1.15	8 lb ice bag (lip) wire wicket	1000	12 x 4	1 Pallet
1015770	12.00 x 21.25 + 1.75	1.15	10 lb ice bag (lip) wire wicket	1000	12 x 4	1 Pallet
1016937	14.00 x 28.00 + 1.50	1.75	20 lb ice bag (lip) wire wicket	500	12 x 4	1 Pallet

Plastic Wicket

Item #	Dimensions (in.) W x L x BG + (Lip)	Gauge (mil)	Description	Case Pack	Ti/Hi	Min. Order
1024866	11.00 x 19.00 x 4.00 + 1.50	1.25	8 lb ice bag plastic wicket	500	12 x 4	1 Pallet
1016934	11.00 x 19.00 x 4.00 + 1.50	1.25	8 lb ice bag plastic wicket	1000	12 x 4	1 Pallet
1026417	12.00 x 19.00 x 4.00 + 1.50	1.25	10 lb ice bag plastic wicket	500	12 x 4	1 pallet
1028258	12.00 x 19.00 x 4.00 + 1.50	1.25	10 lb ice bag plastic wicket	1000	12 x 4	1 Pallet
1016938	14.00 x 26.00 x 4.00 + 1.75	1.75	20 lb ice bag plastic wicket	500	6 x 8	1 Pallet

Drawstring

Item #	Dimensions (in.) W x L	Gauge (mil)	Description	Case Pack	Ti/Hi	Min. Order
1015768	11.00 x 19.00	1.50	8 lb ice bag (hem) drawstring	500	12 x 4	1 Pallet
1028257	12.00 x 19.00	1.50	10 lb ice bag (hem) drawstring	500	12 x 4	1 Pallet
1028261	14.00 x 26.00	2.00	20 lb drawstring	250	6 x 8	1 Pallet

■ Trunk Liners

PERFORMANCE FEATURES

- Easy to tear at the perforations
- Protect your vehicle floor
- Made with minimum 25% recycled material
- Hardware available for dispensing
- 840 Liners per case
- Custom print and color options available. Contact your Hilex sales representative.



Large poly sheets to protect your vehicle

With a single sheet—easily dispensed from a roll at checkout—customers can protect their vehicle interiors.



Roll holding hardware

(Item # 777-3113)

Item #	Dimensions (In.) L x W	Gauge (mic)	Roll Size (in.) Diameter x L	Film Color	Weight (lbs.)	Liners Per Roll	Rolls Per Case	Liners Per Case	Cases/ Pallets	Gross Pallet Weight (lbs.)	Pallets/ Truckload
1005224	38.00 x 52.00	18.00	6.00 x 18.00	Kraft	41.13	210	4	840	32	1371	30

HILEX®

BAG SOLUTIONS FOR BUSINESS



SUSTAINABILITY VISION

The Novolex vision for sustainability is to innovate more sustainable choices for our customers, operate responsibly and invest in our people and communities. We bring this vision to life every day through our ongoing focus on efficiency in our operations, as well as through partnerships with customers, suppliers, communities and others in the industry to develop solutions that reduce the impact our products can have on the environment.

For additional information, please visit www.novolex.com/novolex-sustainability/



www.novolex.com | 800-845-6051 | © August 2024 Novolex

Novolex Corporate Headquarters | 3436 Toringdon Way, Suite 100, Charlotte, NC 28277
H_CA_0027_0824

