



NEW Two-Piece Tamper-Resistant, Tamper-Evident Containers!

Safety, versatility, creativity, freshness, maximum visibility... all in one sleek, square box! The perfect way to securely package a host of applications, from protein boxes to snack packs, salads, sandwiches and so much more!

A TamperAlert™ Tab

Protrudes upwards when torn, alerting the customer that the container has been opened. The tab remains attached to the container, meaning no loose plastic pieces and therefore no littering.

B “Do Not Purchase If Tab Is Torn” Message

Together with TamperAlert™ tab alerts customers to signs of a tampered container

C “Lift” Embossing

Facilitates easy opening by providing guidance on how to open container

D 360° VanishingEdge™ Seal

- Dual purpose seal, specifically designed to
1. Create Tamper Resistance by inhibiting the ability to lift the lid from the base without tearing the tab
 2. Provide a leak resistant seal to maximize freshness and prevent leaks

E CrossSeal™ Compartment Technology

Purposefully designed compartment dividers that prevent migration of contents between compartments

F Smooth Sidewalls

Maximize content visibility

G Stacking Stabilizers

- Dual purpose, precisely positioned in each corner of the lid to
1. Ensure stability of stacked, lidded containers to facilitate merchandisability
 2. Ensure stability of lid stacks and easy one hand separation of each lid from the stack

H Chamfered Corners

Subtly angled corners for reinforced strength



Made of recyclable PET; check locally, may not be recycled in your area.

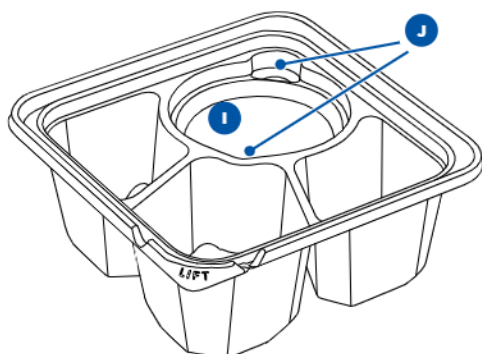
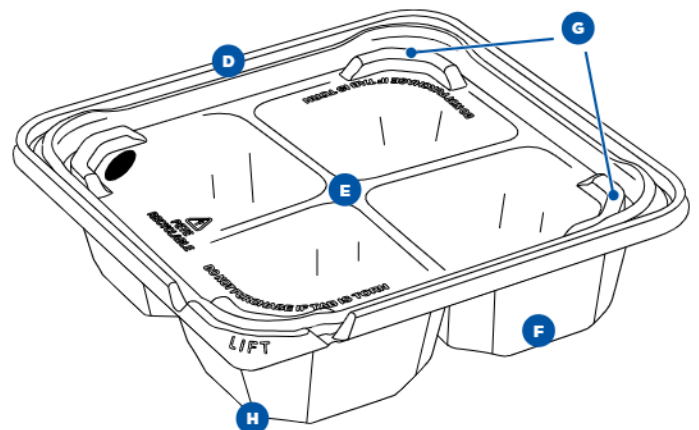
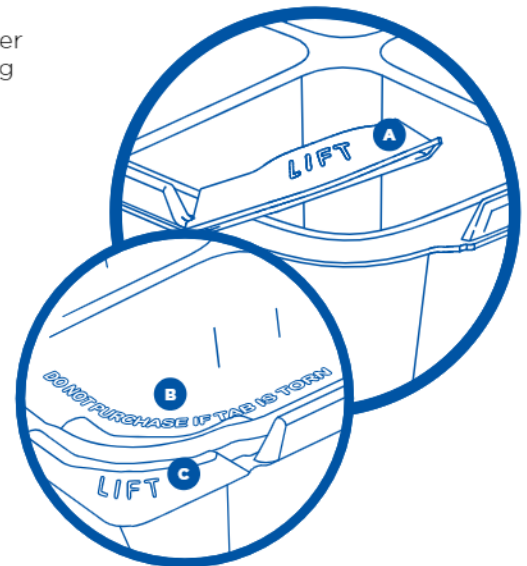

Features unique to our 3-compartment with Well Container (SBTG3W)

I Condiment Compartment

Specifically designed to accept Dart® Conex Complements® and Solo® Ultra Clear™ Soufflés portion containers, either lidded or unlidded, up to 4oz, as well as all conventional pre-sealed portion containers

J ErgoLift™ Contours

Curvatures that create finger space for easier removal of contents from the Condiment Compartment



One Lid Fits 7 Containers

Self aligning closure – Lid fits no matter what direction it's applied!



SBTGRL

1.8 in Deep



SBTG4S

2.1 in Deep



SB24TG1

2.6 in Deep



SB32TG1

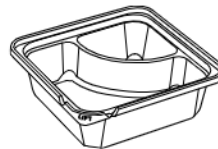

SBTG2

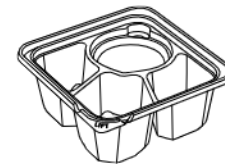

SBTG3W



SBTG3



SBTG4

Stock Number	Description	Outside Dimensions	Sleeve	Case Pack	Case Cube (ft ³)	Case Weight (lbs)	Use With
SB24TG1	24 oz single compartment	6.3" X 6.3" X 2.1"	75	300	2.5	19.2	SBTGRL
SB32TG1	32 oz single compartment	6.3" X 6.3" X 2.6"	75	300	2.6	20.2	
SBTG2	2 Compartment	6.3" X 6.3" X 2.1"	75	300	2.5	19.2	
SBTG3	3 Compartment	6.3" X 6.3" X 2.1"	75	300	2.5	19.2	
SBTG3W	3 Compartment with well	6.3" X 6.3" X 2.6"	75	300	2.6	20.2	
SBTG4	4 Compartment	6.3" X 6.3" X 2.6"	75	300	2.6	20.2	
SBTG4S	4 Compartment, Shallow	6.3" X 6.3" X 1.8"	75	300	2.5	18.5	
Lid							
SBTGRL	Recessed Lid	5.9" X 5.9" X 0.4"	75	300	2.0	9.2	Fits All



For additional information,
contact your Dart representative
or call (800) 248-5960

www.dartcontainer.com

DART CONTAINER CORPORATION

Mason, Michigan 48854 U.S.A.
Ph: (800) 248-5960 • Fax: (517) 676-3883
Email: sales@dart.biz • www.dartcontainer.com

